

# Verana

## INSTALLATION INSTRUCTIONS

### SPC FLOORING

#### Important Notice

Please note that when installing the SPC flooring, please strictly abide by the following requirements, otherwise the loss caused by improper installation will be borne by the buyer!

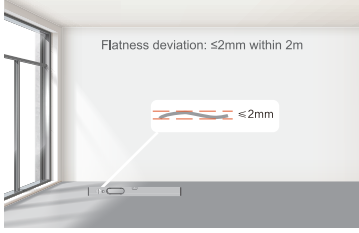

#### Subfloor flatness

**Flatness deviation: ≤2mm within 2m**

All types of subfloors should be level.  
Concrete subfloor need to be self-leveling.

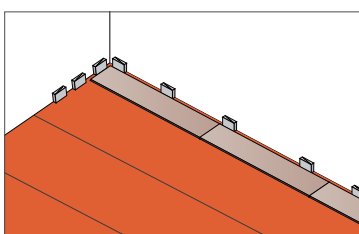

#### Expansion gaps

When installing, it is necessary to reserve expansion gaps between the floor and walls and other objects, under the door frame, etc. The expansion gap needs to be **8-10cm**. In addition, when the maximum laying area is exceeded, expansion gaps are also required. (see page 3 for details)

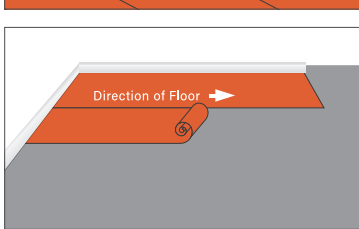

#### Laying moisture barrier

**All types of subfloors require a 6-8 mil moisture barrier** (vapor barrier) prior to installation, and the joints of the vapor barrier need to be sealed with moisture barrier tape.

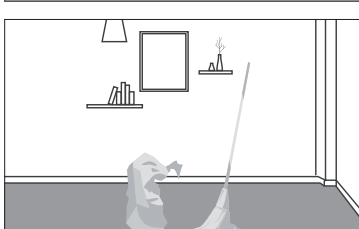

#### Dry & clean subfloor

Remove dust, dirt, etc. from the subfloor to keep it clean. The moisture content of the subfloor is **<14%**, otherwise, dehumidification or appropriate moisture-proof measures should be taken.

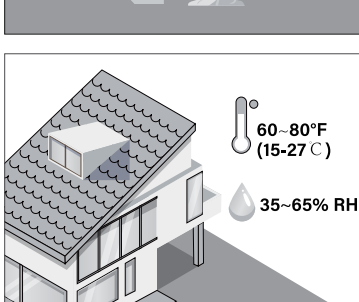

#### Environmental requirements

The ideal indoor temperature is **60-80°F (15-27°C)** and the humidity range is **35-65% RH**. These environmental conditions are specified as pre-installation requirements and must be maintained for the life of the product.

## Applicable subfloor types and requirements

### Wooden subfloor

- If this flooring is intended to be installed over an existing wooden floor, it is recommended to repair any loose boards or squeaks before you begin the installation. Nail or screw every 6" (15 cm) along joists to avoid squeaking.
- We recommend laying on wooden floors crossways to the existing floorboards.
- All other subfloors – Plywood, OSB, particleboard, chipboard, wafer board, etc. must be structurally sound and installed following the manufacturer's recommendations.

### Concrete subfloor

- Floors must be fully cured, at least 60 days old, smooth, permanently dry, clean, and free of all foreign material such as dust, wax, solvents, paint, grease, oils, and old adhesive residue. Curing agents and hardeners could cause bonding failure and should not be used.
- Concrete substrates must be flat. Depressions, deep grooves, expansion joints, and other imperfections must be filled with patching & leveling compound.
- Moisture and alkalinity tests should be performed on all concrete substrates regardless of grade level or age of the slab. Perform either ASTM F2170 In-Situ Relative Humidity (RH) test or ASTM F1869 Calcium Chloride Moisture Test (MVER: Moisture Vapor Emission Rating). Perform a PH test per ASTM F710 to determine the alkalinity of the slab.
- Moisture emission from the subfloor cannot exceed 3 lbs. per 1,000 sq. ft. per 24 hours as measured with the calcium chloride test in accordance with ASTM F1869-04 or ASTM F2170 In-Situ Relative Humidity not to exceed 75%. Applying a polyethylene moisture barrier of at least 6 mils is necessary.

### Existing floors

- The flooring can be installed over most existing hard surface floor coverings, provided the existing floor surface is clean, flat, dry, securely fastened, and structurally sound. Soft floor coverings must be removed. (e.g. carpets)
- Never use solvents or citrus adhesive removers to remove old adhesive residue. The solvent residue left in and on the subfloor may affect the new floor covering.

### DO NOT INSTALL OVER

- Any carpet.
- Floating cushion-backed vinyl flooring.
- Floating floor of any type, loose lay, and perimeter fastened sheet vinyl.
- Hardwood flooring/ wood subfloors that lay directly on concrete or over dimensional lumber or plywood used over concrete.

## Preparation

### 01\_ Measurement and Planning

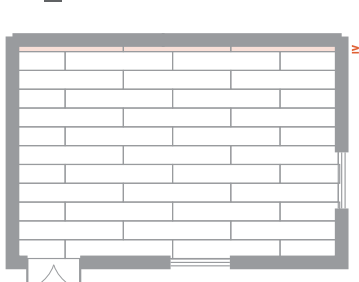

Measure the room area, please reserve **5-10%** more wooden boards for waste and loss.

Please make sure the width of the last row of planks is not less than 50mm, otherwise cut the width of the first row.

### 02\_ Planks acclimation

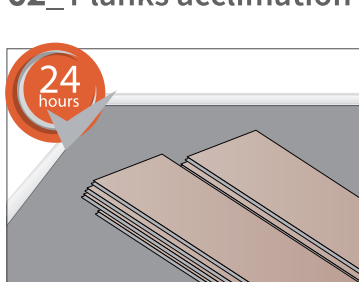

Once your floor arrives, you shouldn't install it right away. The planks are placed on the construction site for at least 24 hours before installation begins, in order to allow the planks to adapt to the site temperature.

### 03\_ Max laying area

SPC flooring has good stability, only when the pavement length/width exceeds 12 m, it needs to be interrupted by expansion gaps. Expansion gaps also need to be reserved at the door and other positions!

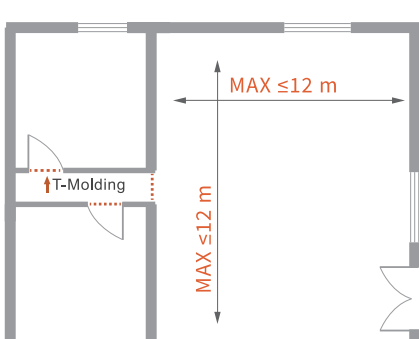

### 04\_ Other details

It is preferable to lay planks following the direction of the main source of light. For the best result, make sure to always work from 2 to 3 cartons at a time, mixing the planks during the installation.

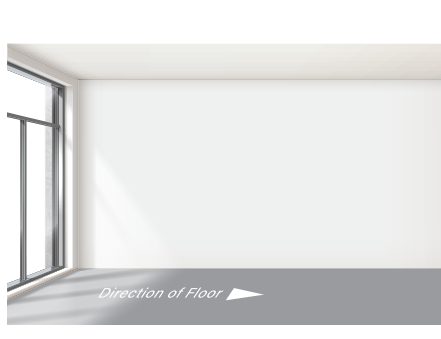

## 05\_ Installation tool

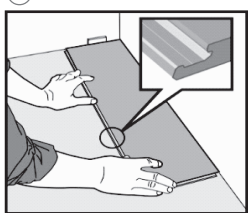

- 

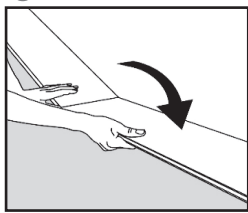
1. Install from the corner of the wall, place the tongue against the wall, and use spacers to keep the distance between the flooring and the wall at **8-10mm**. (The tongue of the first row of flooring needs to be cut off)
- 

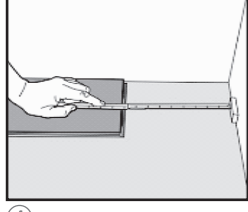
2. Second plank, first row. Drop the plank of short side firstly, and then gently tap down the end with a rubber mallet, so it firmly locks into the previous plank until both are at the same height. Make sure both planks are perfectly aligned. Continue installing the first row until you reach the wall on the right.
- 

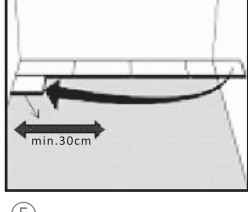
3. At the end of the first row, leave an expansion gap of **8-10mm** to the wall and measure the length of the last plank to fit.
- 

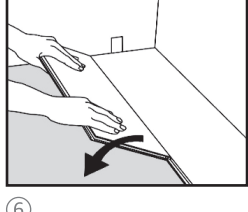
4. Start the second row with the leftover cut part of the last plank of the previous row. This small plank should measure at least **12" (30cm)**. Otherwise, cut a new plank in half and use it to begin the second row. Whenever practical, use the piece cut from the preceding row to start the next row.
- 

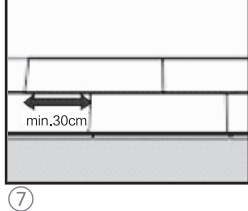
5. The second row of flooring and the ground maintain a **30°** bevel and insert into the previous row. Fold it down and push it forward for a tight fit.
- 

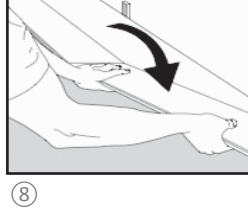
6. The end joints of the all planks should be staggered a minimum of **30cm** apart.
- 

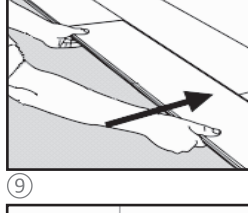
7. Click the short side and place it tight to the short end of the left plank.
- 

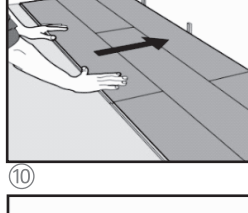
8. Then click the long side of the flooring. Push the flooring forward, making sure the two pieces are firmly connected.
- 

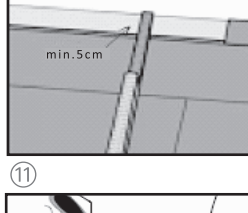
9. After the first 2-3 rows of planks are installed, they should be checked with a string line to ensure that rows are still running straight. If they are not, it could be that the starting wall has some irregularities that caused bowing in the installation.
- 

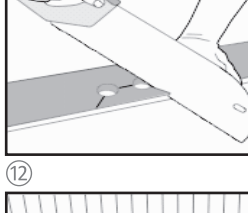
10. Please note that the flooring of the last row is at least **5cm** from the wall.
- 

11. Drilling holes which there is a vertical object, and make sure the holes are bigger than the width of object;
- 

12. Cutting the small area and fill into the inner side.

## Finishing the installation

Replace molding or wall base, allowing slight clearance between the molding and the planks. Nail the molding to the wall surface, not through the flooring. At doorways and at other areas where the flooring planks may meet other flooring surfaces, it is preferable to use a "T" molding, or similar, to cover the exposed edge but not pinch the planks. Leave a small gap between the planks and the adjoining surface.

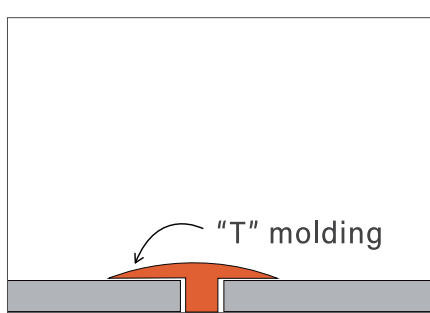
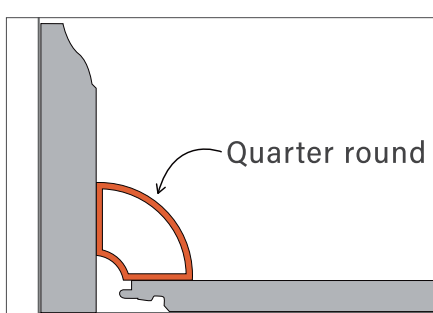

## Disassemble

Separate the whole row by lifting it up delicately at an angle. To separate the planks, leave them flat on the ground and slide them apart. If planks do not separate easily, you can slightly lift up the planks (5°) when sliding them apart.

